

Vibromak[®]

Surface finishing
technologies.



ROTARY VIBRATORY MACHINES VKU SERIES

The ideal solution for deburring and polishing
the surface of mass produced parts.



FOR MORE INFO
PLEASE CONTACT
branko@massfin.ca
1(519)739-0733

Test Lab Address: 4325 County Rd. 42, Windsor, Ontario, N9A 6J3

WWW.MASSFIN.CA

www.massfin.ca

Vibratory Surface Finishing Machines without Separator



Additional Accesories:

- Pneumatic Sound Cover
- Pneumatic Unload Gate
- Frequency Control
- Dossage Pump
- Magnetic Valve
- Control Panel Base
- Rinsing Pipe (Different Types)
- Paddle Wheel

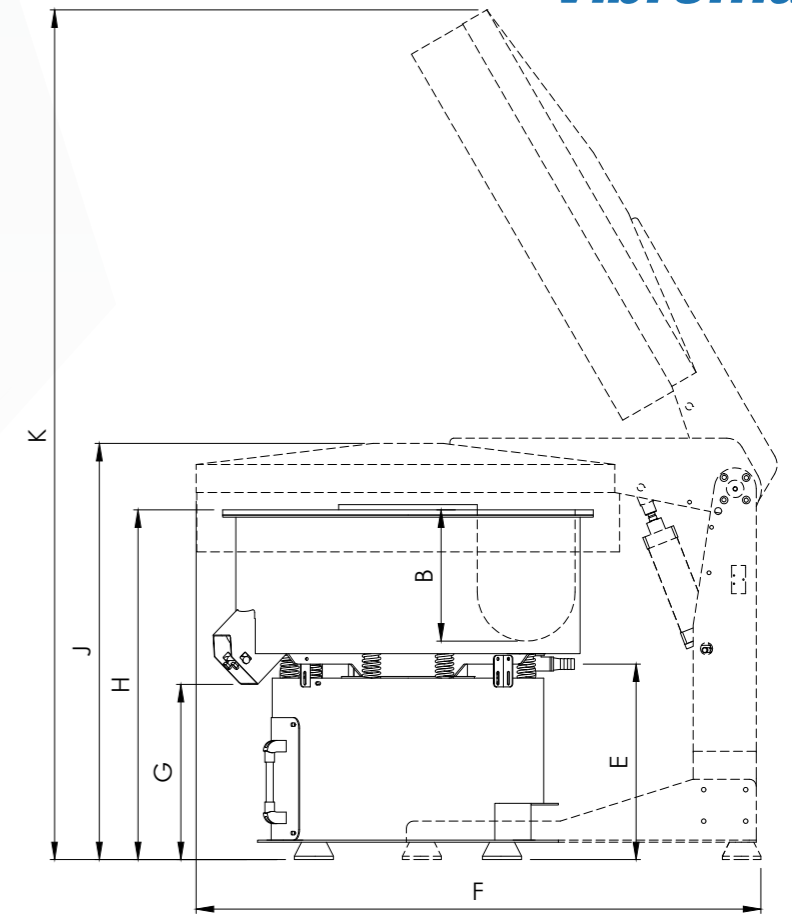
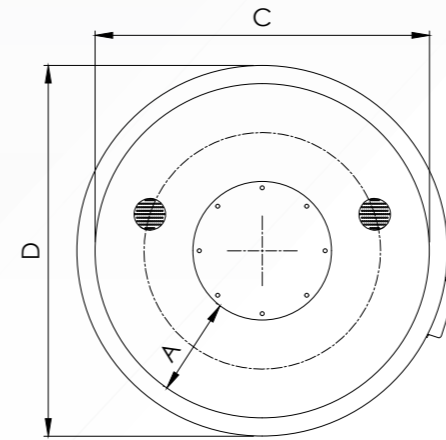

VKU series machines can be used for surface finishing of metal and nonmetal work pieces. These type of machines do not have a separation screen. Generally used for big volume and delicate surfaced work pieces.

Technical Dimensions

TYPE		VKU 25	VKU 50	VKU 100	VKU 200	VKU 400	VKU 600	VKU 800	VKU 1000	VKU 1200
Gross Volume	Lt	25	51	102	210	408	610	820	1010	1230
PU Thickness	mm	15-25	15-25	15-25	15-25	15-25	15-25	15-25	15-25	15-25
Engine Power	Kw	0.35	0.6	0.7	1.1	1.9	2.5	5	7	7
Voltage	V/Hz	380/50	380/50	380/50	380/50	380/50	380/50	380/50	380/50	380/50
Operating Speed	rpm	1500	1500	1500	1500	1500	1500	1500	1500	1500
Weight	Kg	110	140	220	350	600	820	1050	1220	1380
A	mm	140	210	250	280	360	400	460	490	550
B	mm	185	215	300	375	460	520	575	630	650
C	mm	510	610	730	950	1200	1410	1560	1630	1750
D	mm	580	700	820	1060	1310	1530	1680	1780	1900
E	mm	550	600	500	550	550	500	500	500	500
F	mm	--	--	1220	1620	1900	2100	2320	2400	2550
G	mm	--	--	500	525	525	450	450	450	450
H	mm	830	900	900	1050	1100	1100	1250	1250	1250
J	mm	--	--	1100	1230	1300	1300	1450	1450	1450
K	mm	--	--	2000	2600	2900	3050	3300	3400	3500



Media Unload Gate



Water and Compound Inlet Valve



Dirty Water Discharge Valve



Machine Springs



Electrical Control Panel